

# Emissions Filter Takes the Heat

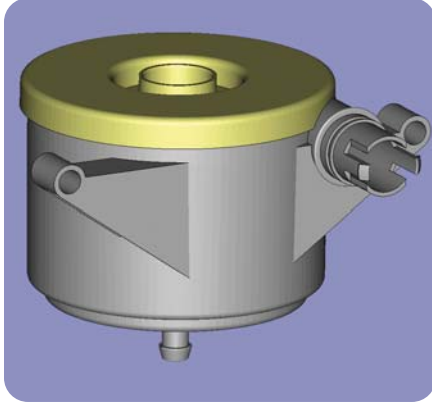

## Automotive-Filter Maker Tests PPSF Prototype on V8 Engine

*“Vibration affects filter efficiency, so it was important to mount the prototype directly on the engine for accurate testing.”*

- Russ Jensen, Parker Hannifin — Racor

Parker Hannifin's Racor division recently designed an emissions filter that enables diesel engine manufacturers to meet new emission requirements. The company used its FDM Titan™ prototyping system to create a PPSF (polyphenylsulfone) prototype of the filter. The filter, called a crankcase vapor coalescer, was used for functional design testing.

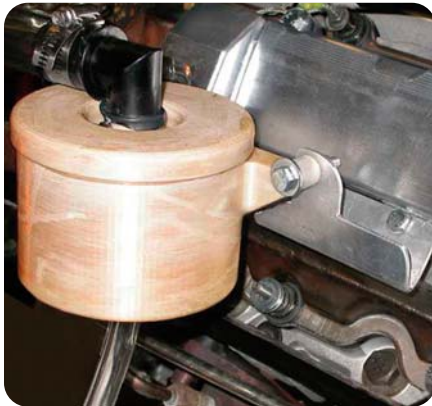

The PPSF prototype was durable enough to mount directly on the valve cover of a 6.0-liter V8 diesel engine and test at various loads for 78 hours. “The prototype filter collected blow-by gases containing 160°F (71°C) oil, fuel, soot, and other combustion by-products,” says Racor senior development engineer Russ Jensen. “It withstood the operating environment and heat of the engine.”

“Aside from some staining, the part appears to have the same strength and properties as when it was first assembled. We never saw a leak from this assembly, and we were very pleased with its performance.”

Images 1: CAD model of Parker Hannifin emissions filter. Image 2: Photo of PPSF prototype mounted on V8 engine.

Racor was a Stratasys beta-test site that helped prove out the capabilities of PPSF prior to its commercialization as a rapid prototyping material. Racor was interested in PPSF because it can handle heat near 400°F (204°C), it resists petroleum products, acids, and bases, and its strength is superior to other prototyping thermoplastics.

For more information about Stratasys systems and materials, contact your representative at +1 888.480.3548 or visit [www.stratasys.com](http://www.stratasys.com)

---

**Stratasys Inc.**

7665 Commerce Way  
Eden Prairie, MN 55344  
+1 888 480 3548 (US Toll Free)  
+1 952 937 3000  
+1 952 937 0070 (Fax)  
[www.stratasys.com](http://www.stratasys.com)  
[info@stratasys.com](mailto:info@stratasys.com)

**Stratasys GmbH**

Weismüllerstrasse 27  
60314 Frankfurt am Main  
Germany  
+49 69 420 9943 0 (Tel)  
+49 69 420 9943 33 (Fax)  
[europe@stratasys.com](mailto:europe@stratasys.com)